

SENSORS

CURRENT & VOLTAGE MEASUREMENT
FOR THE GRID OF THE FUTURE



PRODUCT OVERVIEW - CURRENT & VOLTAGE MEASUREMENT

WINDOW TYPE CURRENT SENSORS



SPLIT CORE CURRENT SENSORS



VOLTAGE SENSORS INDOOR

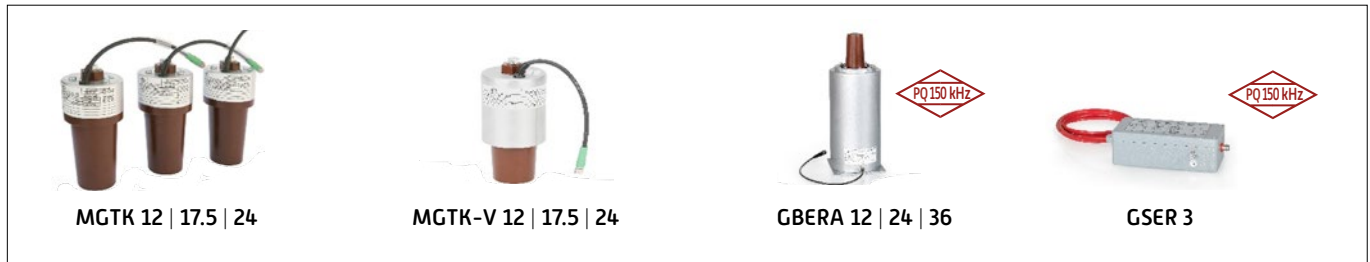

VOLTAGE SENSORS OUTDOOR



COMBINED SENSORS



TABLE OF CONTENTS

1.0 DESIGN AND PROPERTIES OF SENSORS	P. 4
1.1 What Are Sensors?	P. 4
1.2 Current Transformer Or Current Sensor?	P. 4
1.3 Voltage Transformer Or Voltage Sensor?	P. 4
1.4 Sensors And Power Quality	P. 4
2.0 WINDOW TYPE CURRENT SENSORS	P. 5
2.1 KSOH-S 1082	P. 5
2.2 MKSOH-S 1384	P. 6
2.3 KSR-S 60 Size 1	P. 7
3.0 SPLIT CORE CURRENT SENSORS	P. 8
3.1 UGSS-S 104 Size 1	P. 8
3.2 RKU-S 2012	P. 9
4.0 VOLTAGE SENSORS INDOOR	P. 10
4.1 MGTK 12 17.5 24	P. 10
4.2 MGTK-V 12 17.5 24	P. 11
4.3 GBERA 12 24 36	P. 12
4.4 GSER 3	P. 13
5.0 VOLTAGE SENSORS OUTDOOR	P. 14
5.1 GSER(F) 16	P. 14
5.2 GSER(F) 52	P. 15
5.3 GSR 27 38	P. 16
6.0 COMBINED SENSORS	P. 17
6.1 ABS 12 17.5 24 36	P. 17
7.0 APPENDIX 1: SECONDARY TERMINALS	P. 18
8.0 APPENDIX 2: Accuracy Classes According To Iec 61869	P. 19
8.1 Limits At Rated Frequency	P. 19
8.2 Limits For Harmonics	P. 20
8.3 Accuracy Depending On Primary Conductor Position	P. 21
RITZ INSTRUMENT TRANSFORMERS GMBH	P. 22
GROUP HISTORY	P. 23

1.0 DESIGN AND PROPERTIES OF SENSORS

1.1 WHAT ARE SENSORS?

In power engineering, instrument transformers based on the inductive principle are used to measure current and voltage. In addition to these conventional instrument transformers, there are other, non-conventional instrument transformers, some of which use other operating principles. RITZ generally refers to the passive versions under the umbrella term „sensors“. They are characterised by the following properties:

- Sensors only transfer low power levels, typically ≤ 1 VA.
- Sensors have a voltage output. Standard values are 22.5 mV, 150 mV or 225 mV for current sensors and $3.25/\sqrt{3}$ V for voltage sensors.
- Sensors can exhibit improved linearity characteristics over a wide dynamic range.

1.2 CURRENT TRANSFORMER OR CURRENT SENSOR?

Current sensors are output-matched, inductive current transformers with integrated burden or Rogowski coils. The voltage signal at the output is proportional to the primary current or, in the case of Rogowski coils, proportional to the derivative of the primary current. In this case, an electronic system is required on the secondary side, which integrates the voltage signal. This is important so that the actual mains frequency does not influence the measurement result. As with current transformers, current sensors can only measure alternating currents, in accordance with the principles described above. The small integrated burden of inductive current sensors allows reduced core dimensions and therefore smaller sizes. Saturation effects can occur with these current sensors, as is also the case with current transformers. Rogowski coils cannot saturate since they are wound over an air core as opposed to an iron core. Just like current transformers, current sensors do not require any auxi-

liary power and are maintenance-free. All current sensors from RITZ undergo a routine test before delivery.

1.3 VOLTAGE TRANSFORMER OR VOLTAGE SENSOR?

Voltage sensors consist of a resistive, resistive-capacitive or capacitive voltage divider. This divides the primary voltage such that a low voltage proportional to the primary voltage is applied at the output. In this way, not only alternating but also direct voltages can be measured. In contrast to a voltage transformer, a voltage sensor does not have galvanic isolation between the primary and secondary sides, so there are integrated surge arresters to protect the downstream devices. The accuracy of voltage sensors is influenced both by the connected burden and by the type and length of the connecting cable. The stated accuracy therefore only applies to the specified condition. Just like voltage transformers, voltage sensors do not require any auxiliary power and are maintenance-free. All voltage sensors from RITZ undergo a routine test before delivery.

1.4 SENSORS AND POWER QUALITY

The term „power quality“ is generally used to describe the electrical energy quality of electrical networks. In addition to an uninterruptible supply, this includes high current and voltage quality with low flicker, transients and harmonics, as well as a constant mains frequency. Sensors can be used to measure harmonics in order to determine current and voltage quality. These are referred to as „PQ measurements“ and can be carried out with sensors that have transmission characteristics optimised for accurate measurement results even at frequencies in the kHz range. Sensors suitable for PQ measurements are marked in the catalogue with a corresponding symbol. Depending on the sensor, up to three frequency options are available: 3 kHz, 9 kHz und 150 kHz.

	Transformer	Sensor
Power	Up to several 100 VA	≤ 1 VA
Output signal	Current or voltage	Voltage
Standard values	1 A 5 A	22.5 mV 150 mV 225 mV
Output	or $100/\sqrt{3}$ V $110/\sqrt{3}$ V	or $3.25/\sqrt{3}$ V
Primary variable	AC	DC and/or AC
Electrical isolation	Yes	Partially
Frequency	16.7 Hz 50 Hz 60 Hz + frequency option up to 9 kHz	0 Hz 16.7 Hz 50 Hz 60 Hz + frequency option up to 150 kHz

2.0 WINDOW TYPE CURRENT SENSORS

2.1 KSOH-S 1082

Low power passive current transformer according to IEC 61869-10

- For installation in local network stations
- Straightforward installation
- With earth terminal

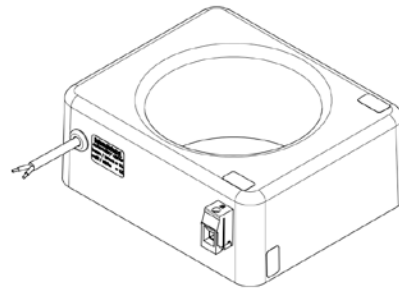

TYPE

KSOH-S 1082

Rated frequency f_r	50 Hz 60 Hz
Rated insulation level	0,72/3/- kV
Temperature category	-5 °C / +40 °C
Mass	1,0 kg
Insulating class	A
Insulation level at secondary terminals	820/1500 V
Rated primary current I_{pr}	300 A
Rated secondary voltage U_{sr}	225 mV
Factor of the extended primary rated current $K_{p cr}$	2
Thermal short-time rated current I_{th}	25 kA 3 s
Rated peak current I_{dyn}	63 kA
Rated continuous thermal current I_{cth}	600 A
Accuracy class	0,2-A3 * 0,5-A3 * / 5P 6000 A
Output signal	proportional
Rated burden R_{br}	2 M Ω / 50 pF
Rated phase offset φ_{or}	0°

* See 8.3 Accuracy depending on primary conductor position

DIMENSIONAL DRAWING

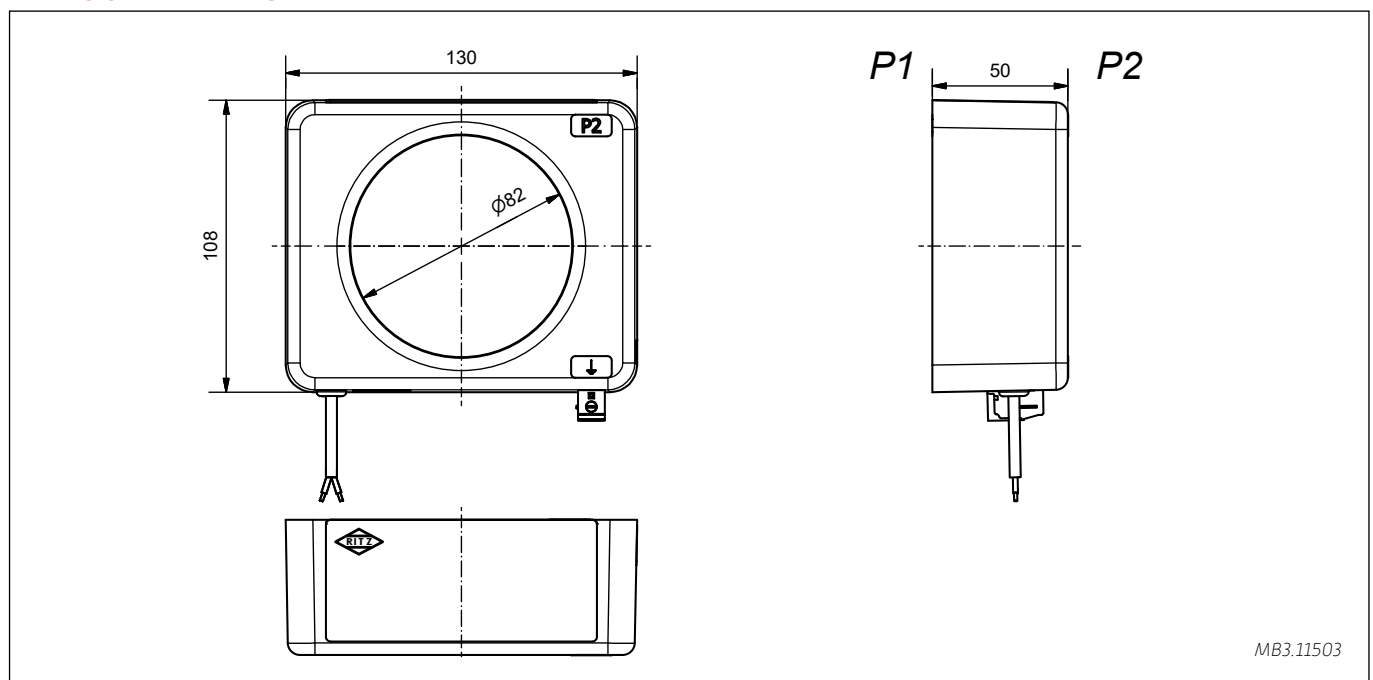

MB3.11503

For more information, please refer to the data sheet. Subject to technical modifications. NOTE: For possible secondary cables refer to Appendix 1

WINDOW TYPE CURRENT SENSORS

2.2 MKSOH-S 1384

Low power passive current transformer according to IEC 61869-10

- Compact solution
- 3 phase current sensors
- 1 earth fault detection sensor

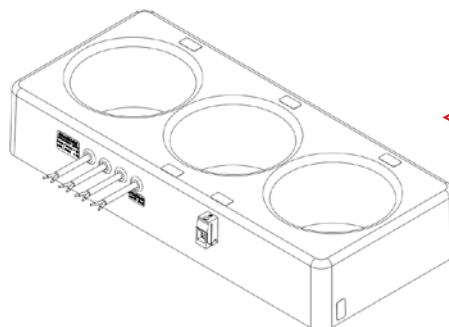

TYPE	MKSOH-S 1384	
	PHASE CURRENT	EARTH FAULT
Rated frequency f_r	50 Hz 60 Hz	
Rated insulation level	0,72/3/- kV	
Temperature category	-5 °C / +40 °C	
Mass	2,8 kg	
Insulating class	A	
Insulation level at secondary terminals	820/1500 V	
Rated primary current I_{pr}	300 A	60 A
Rated secondary voltage U_{sr}	225 mV	
Factor of the extended primary rated current K_{pccr}	2	
Thermal short-time rated current I_{th}	25 kA 3 s	
Rated peak current I_{dyn}	63 kA	
Rated continuous thermal current I_{cth}	600 A	120 A
Accuracy class	0,5-A3 * / 5P 3000 A	1-A3 *
Output signal	proportional	
Rated burden R_{br}	2 MΩ / 50 pF	
Rated phase offset φ_{or}	0°	

* See 8.3 Accuracy depending on primary conductor position

DIMENSIONAL DRAWING

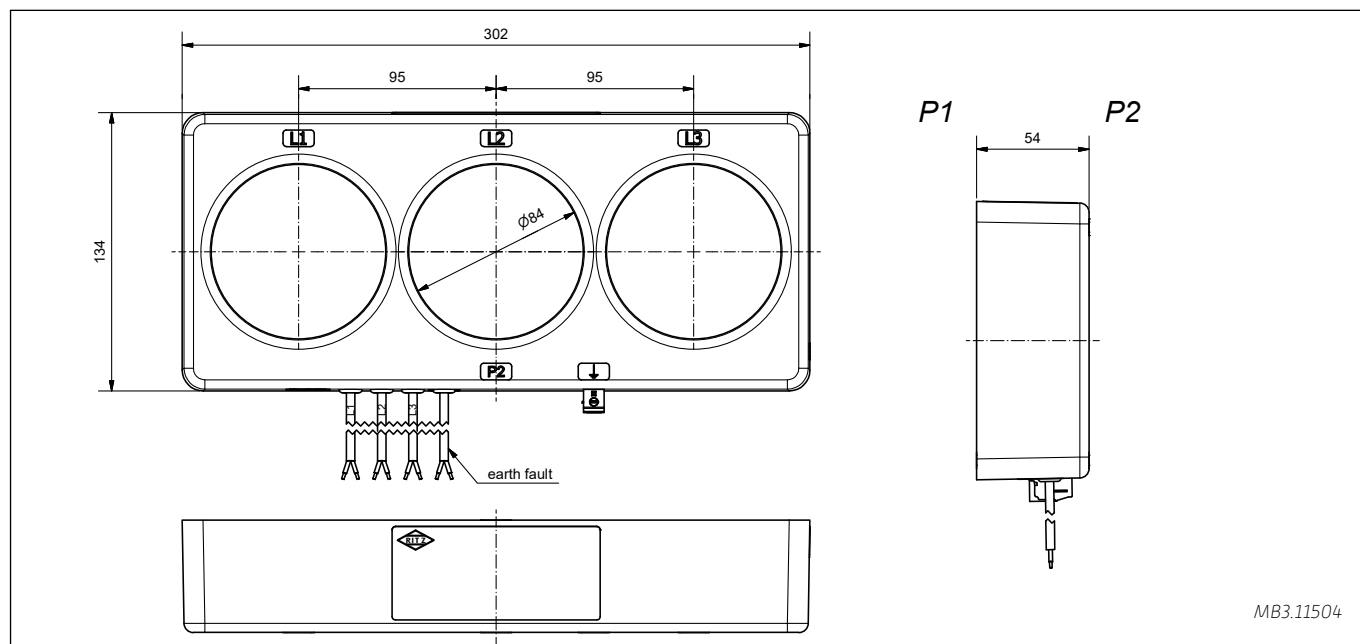

MB3.11504

For more information, please refer to the data sheet. Subject to technical modifications. NOTE: For possible secondary cables refer to Appendix 1

WINDOW TYPE CURRENT SENSORS

2.3 KSR-S 60 size 1

Low power passive current transformer according to IEC 61869-10

- Removable copper pipe for round conductors 16 mm
- Standard accessories: transparent terminal cover
- The transformer can be installed in any position

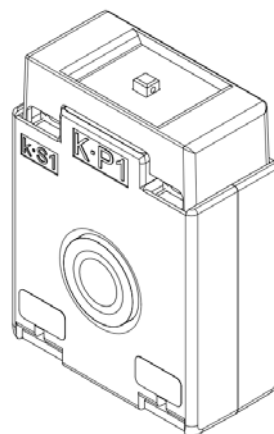

TYPE

KSR-S 60 size 1

Rated frequency f_r	50 Hz *
Insulation level	0,72/3/- kV
Temperature category	-5 °C / +40 °C
Mass	<0,4 kg
Insulating class	E
Insulation level at secondary terminals	820/1500 V
Rated primary current I_{pr}	100 A 150 A 200 A 250 A 300 A 400 A *
Rated secondary voltage U_{sr}	330 mV*
Factor of the extended primary rated current K_{pcr}	1
Rated short-time thermal current I_{th}	60 I_{pr}
Rated peak current I_{dyn}	100 kA
Rated short-time thermal current I_{cth}	100% x I_{pr} *
Accuracy class	0,5-A1 *
Output signal	proportional
Rated burden R_{br}	2 MΩ / 50pF
Rated phase offset φ_{or}	0°

* Other values available on request

DIMENSIONAL DRAWING

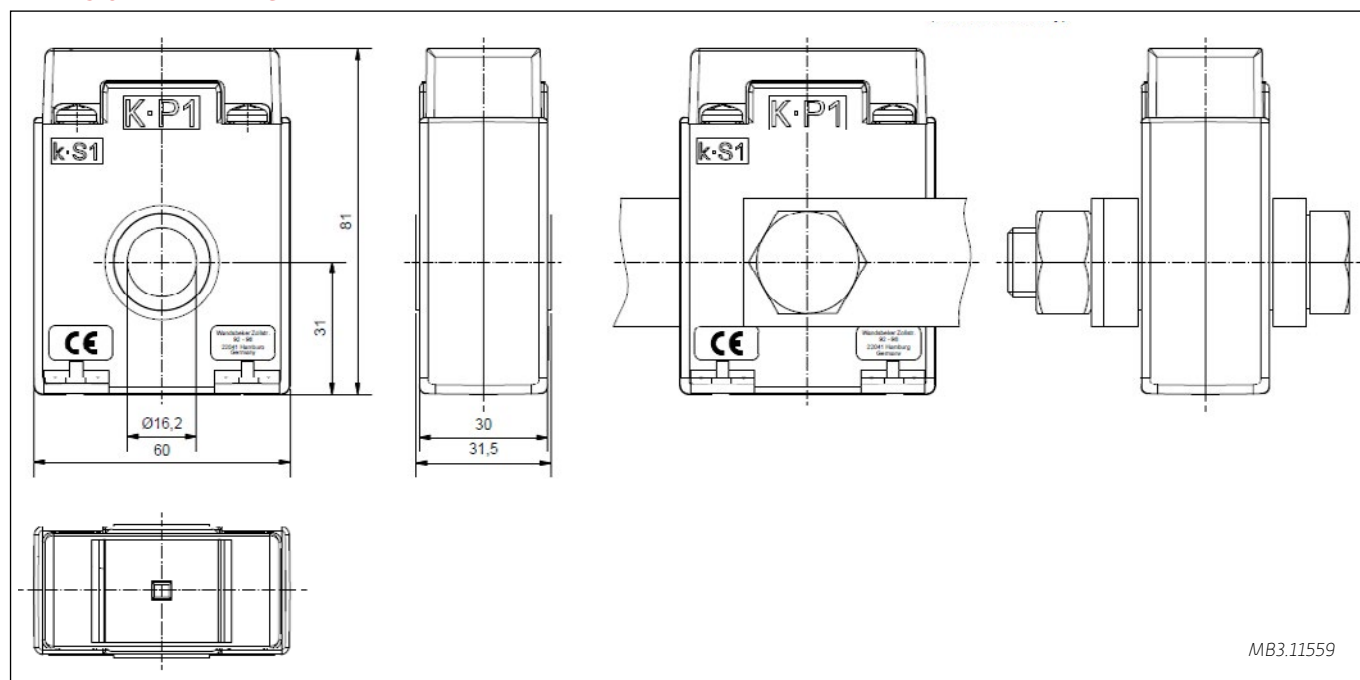

MB3.11559

For more information, please refer to the data sheet. Subject to technical modifications. NOTE: For possible secondary cables refer to Appendix 1

3.0 SPLIT CORE CURRENT SENSORS

3.1 UGSS-S 104 size 1

Low power passive current transformer according to IEC 61869-10

- For retrofitting
- Straightforward installation
- Can be split

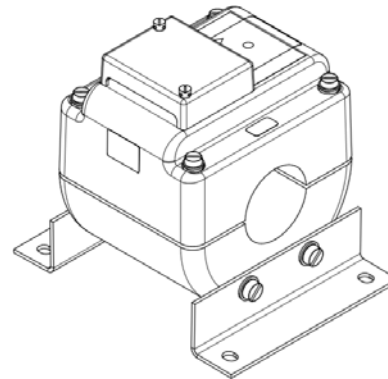

TYPE

UGSS-S 104 size 1

Rated frequency f_r	50 Hz 60 Hz
Rated insulation level	0,72/3/- kV
Temperature category	-5 °C / +40 °C
Mass	1,7 kg
Insulating class	E
Insulation level at secondary terminals	820/1500 V
Rated primary current I_{pr}	300 A
Rated secondary voltage U_{sr}	225 mV
Factor of the extended primary rated current K_{pcr}	2
Thermal short-time rated current I_{th}	25 kA 3 s
Rated peak current I_{dyn}	63 kA
Rated short-time thermal current I_{cth}	600 A
Accuracy class	0,5-A2 * / 5P 3000 A
Output signal	proportional
Rated burden R_{br}	2 MΩ / 50 pF
Rated phase offset φ_{or}	0°

* See 8.3 Accuracy depending on primary conductor position

DIMENSIONAL DRAWING

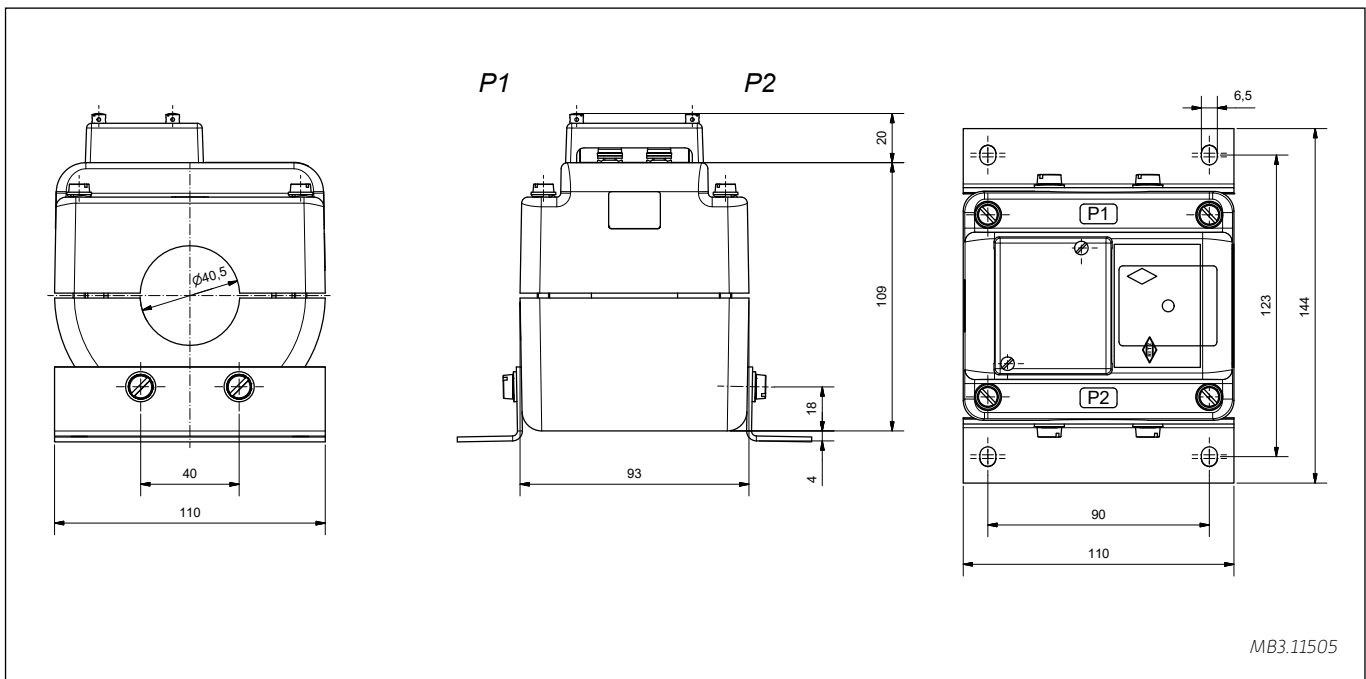

MB3.11505

For more information, please refer to the data sheet. Subject to technical modifications. NOTE: For possible secondary cables refer to Appendix 1

SPLIT CORE CURRENT SENSORS

3.2 RKU-S 2012

Low power passive current transformer according to IEC 61869-10

- For retrofitting
- Straightforward installation
- Can be split

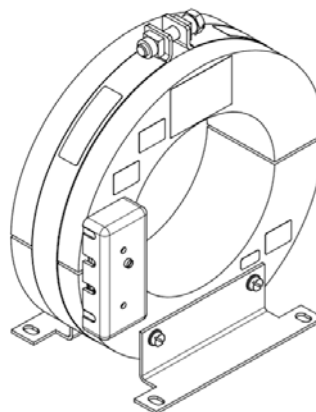

TYPE

RKU-S 2012

Rated frequency f_r	50 Hz 60 Hz
Rated insulation level	0,72/3/- kV
Temperature category	-5 °C / +40 °C
Mass	2,7 kg
Insulating class	E
Insulation level at secondary terminals	820/1500 V
Rated primary current I_{pr}	60 A
Rated secondary voltage U_{sr}	225 mV
Factor of the extended primary rated current K_{pcr}	2
Rated short-time thermal current I_{th}	25 kA 3 s
Rated peak current I_{dyn}	63 kA
Rated short-time thermal current I_{cth}	120 A
Accuracy class	0,5-A3 * / 5P 600 A
Output signal	proportional
Rated burden R_{br}	2 M Ω / 50 pF
Rated phase offset φ_{or}	0°

* See 8.3 Accuracy depending on primary conductor position

DIMENSIONAL DRAWING

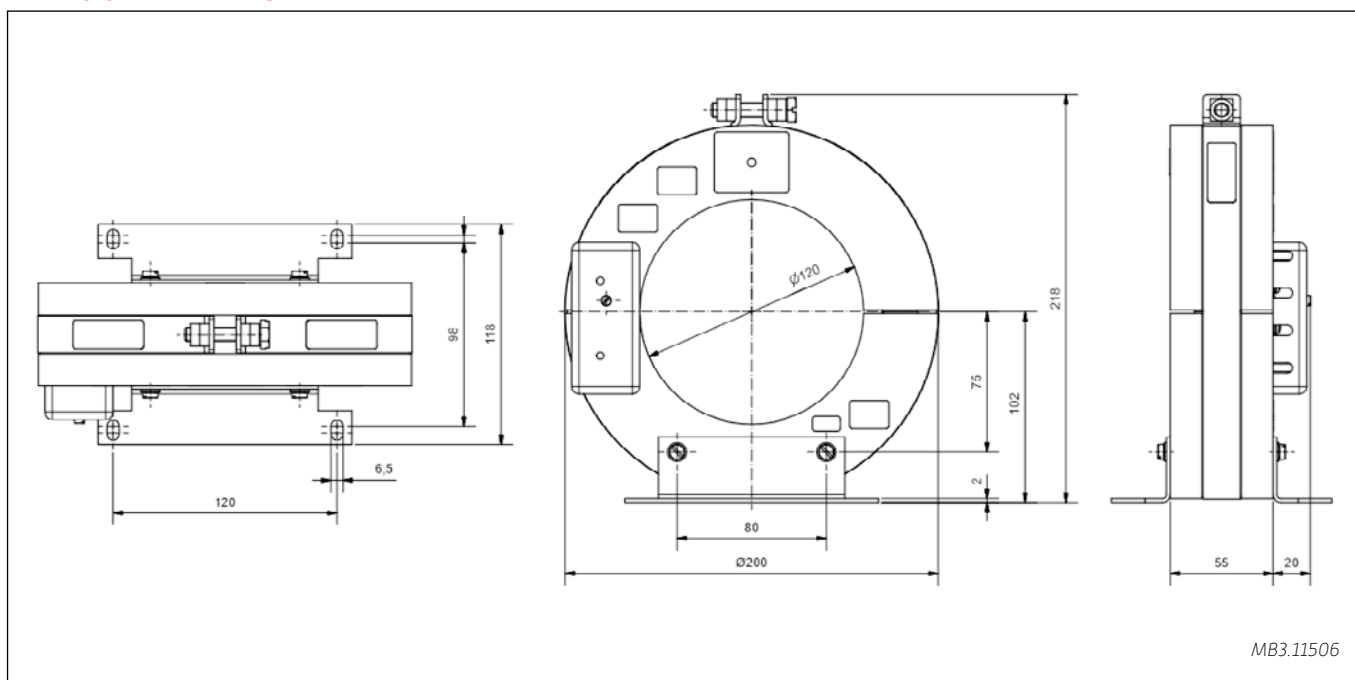

For more information, please refer to the data sheet. Subject to technical modifications. NOTE: For possible secondary cables refer to Appendix 1

4.0 VOLTAGE SENSORS – INDOOR

4.1 MGTK 12 | 17.5 | 24 | 36

Low power passive voltage transformer according to IEC 61869-11

- Primary terminal outer cone type C according to EN 50181
- For installation in symmetrical T-connectors
- Suitable for BBC Cellpack CTS-S 630 A 24 kV

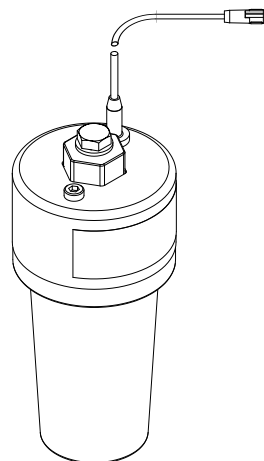

TYPES	MGTK 12	MGTK 17.5	MGTK 24	MGTK 36
Rated frequency f_r	50 Hz 60 Hz			
Rated insulation level	12/28/75 kV	17,5/38/95 kV	24/50/125 kV	36/70/170 kV
Temperature category	-25°C / +40°C			
Mass	1 kg			
Insulating class	E			
Insulation level at secondary terminals	n/a			
Rated primary voltage U_{pr}	10/ $\sqrt{3}$ kV	15/ $\sqrt{3}$ kV	20/ $\sqrt{3}$ kV	30/ $\sqrt{3}$ kV
Rated secondary voltage U_{sr}	3,25/ $\sqrt{3}$ V			
Rated voltage factor FV	1,2 / 1,9 8 h			
Rated burden R_{br}	200 k Ω \pm 1 % *			
Accuracy class	0,5/3P			
Rated phase offset φ_{or}	0°			

* Other values available on request

DIMENSIONAL DRAWING

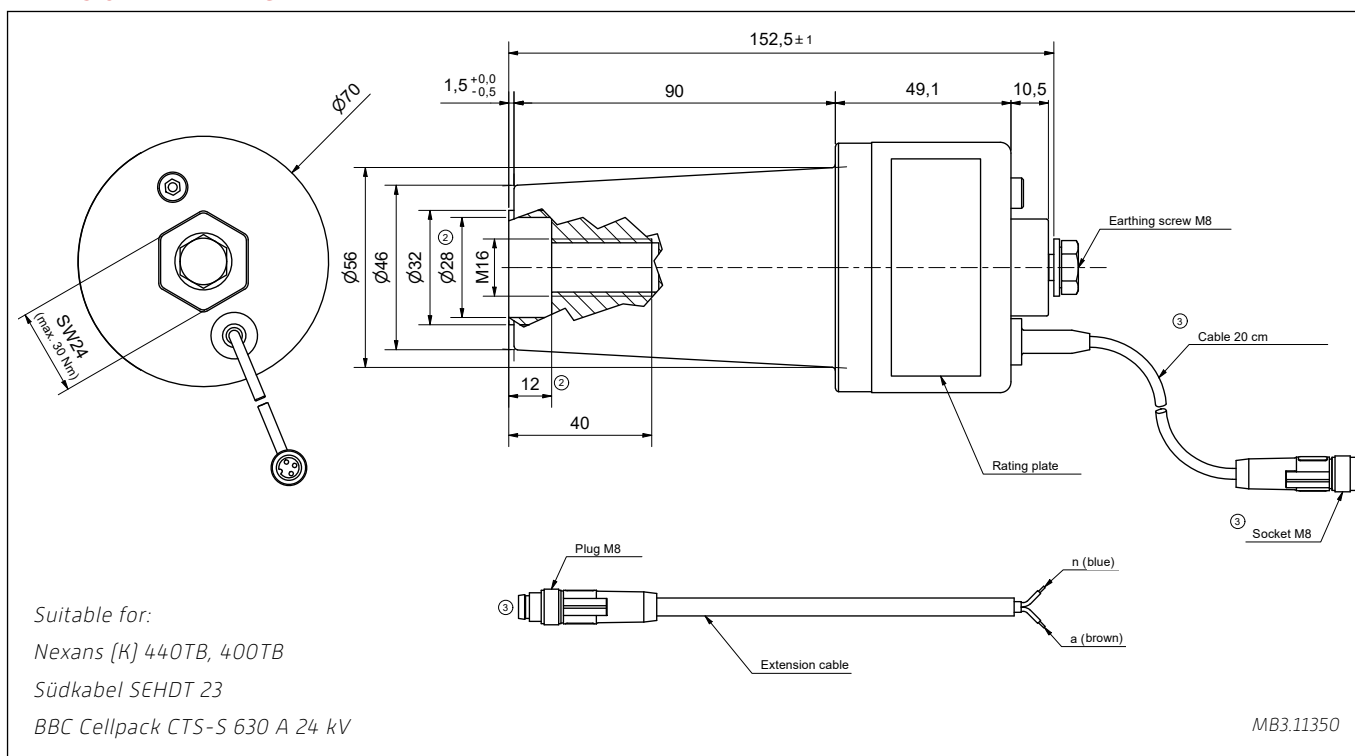

For more information, please refer to the data sheet. Subject to technical modifications. NOTE: For possible secondary cables refer to Appendix 1

VOLTAGE SENSORS – INDOOR

4.2 MGTK-V 12 | 17.5 | 24

Low power passive voltage transformer according to IEC 61869-11

- Primary terminal outer cone shortened
- For installation in asymmetrical T-connectors

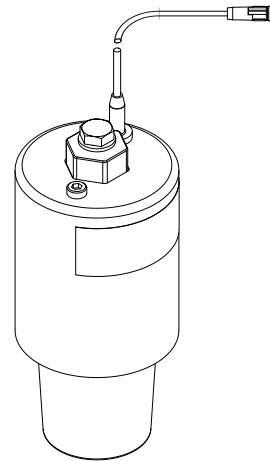

TYPES	MGTK-V 12	MGTK-V 17.5	MGTK-V 24
Rated frequency f_r		50 Hz 60 Hz	
Rated insulation level	12/28/75 kV	17,5/38/95 kV	24/50/125 kV
Temperature category		-25°C / +40°C	
Mass		1 kg	
Insulating class		E	
Insulation level at secondary terminals		n/a	
Rated primary voltage U_{pr}	10/ $\sqrt{3}$ kV	15/ $\sqrt{3}$ kV	20/ $\sqrt{3}$ kV
Rated secondary voltage U_{sr}		3,25/ $\sqrt{3}$ V	
Rated voltage factor F_v		1,2 / 1,9 8 h	
Rated burden R_{br}		200 k Ω \pm 1 % *	
Accuracy class		0,5/3P	
Rated phase offset φ_{or}		0°	

* Other values available on request

DIMENSIONAL DRAWING

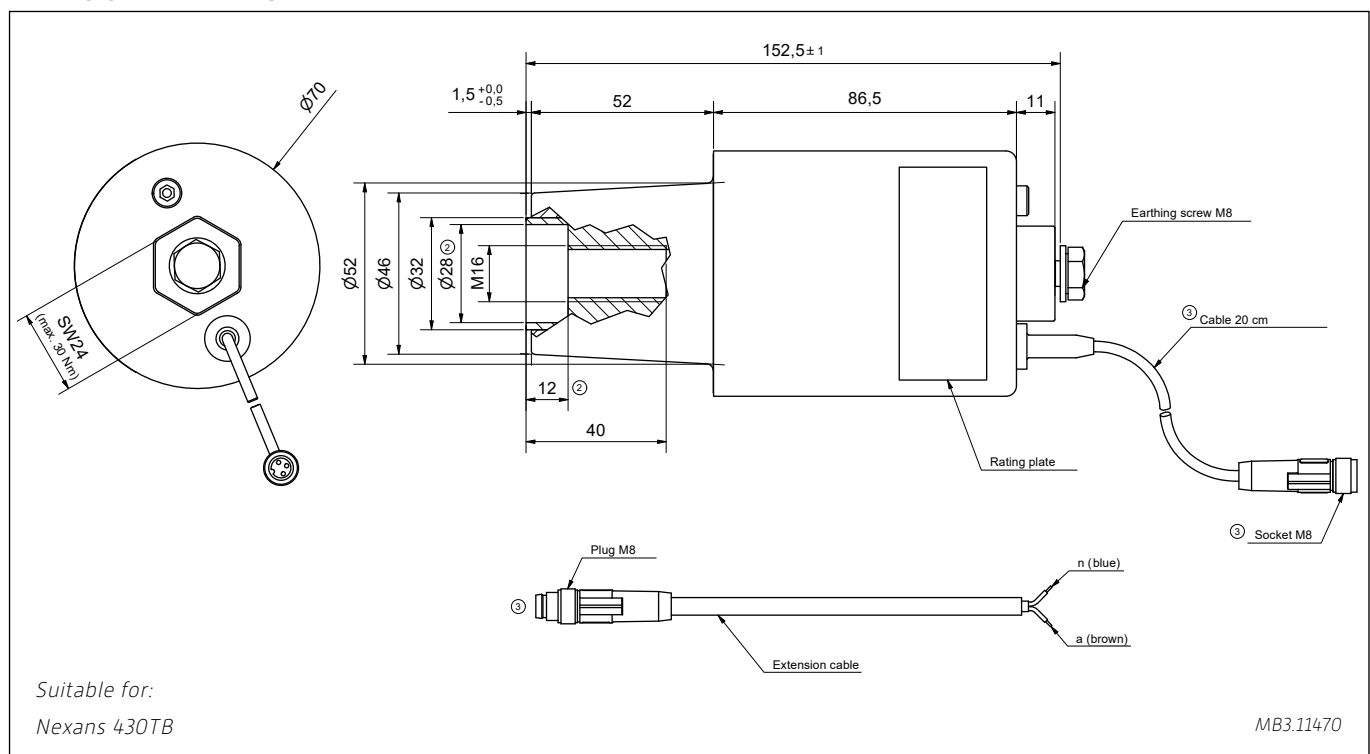

For more information, please refer to the data sheet. Subject to technical modifications. NOTE: For possible secondary cables refer to Appendix 1

VOLTAGE SENSORS – INDOOR

4.3 GBERA 12 | 24 | 36

Low power passive voltage transformer according to IEC 61869-11

- Primary terminal outer cone type C according to EN 50181
- Metal-clad
- Suitable for PQ measurements

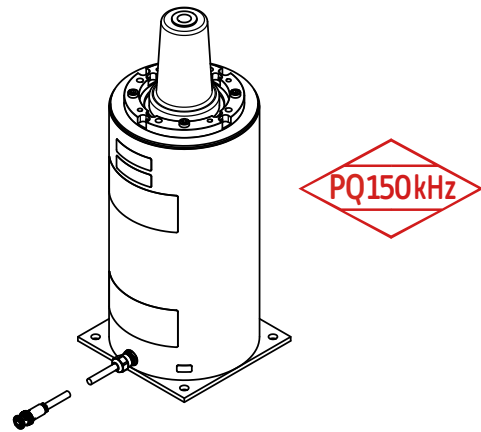

TYPES	GBERA 12	GBERA 24	GBERA 36
Rated frequency f_r	50 Hz 60 Hz *		
Rated insulation level	12/28/75 kV	24/50/125 kV	36/70/170 kV
Temperature category	-5 °C / +40 °C		
Mass	9 kg		
Insulating class	E		
Insulation level at secondary terminals	n/a		
Rated primary voltage U_{pr}	10/ $\sqrt{3}$ kV *	20/ $\sqrt{3}$ kV *	30/ $\sqrt{3}$ kV *
Rated secondary voltage U_{sr}	3,25/ $\sqrt{3}$ V *		
Rated voltage factor F_V	1,2 / 1,9 8 h		
Rated burden R_{br}	2 M Ω / 50 pF *		
Accuracy class	0,5P		
Rated phase offset φ_{or}	0°		

* Other values available on request

DIMENSIONAL DRAWING

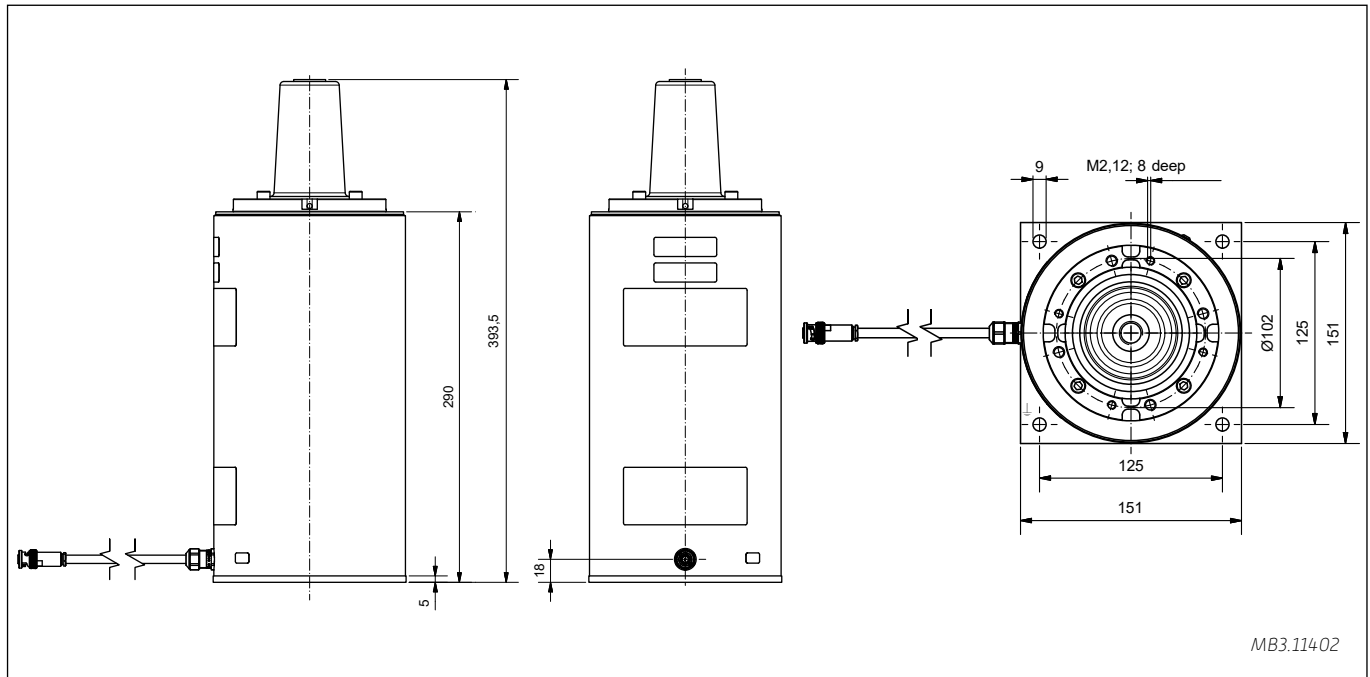

For more information, please refer to the data sheet. Subject to technical modifications. NOTE: For possible secondary cables refer to Appendix 1

VOLTAGE SENSORS – INDOOR

4.4 GSER 3

Low power passive voltage transformer according to IEC 61869-11

- For high-precision measurements with class 0.1
- Accessories for power analysers
- Suitable for PQ measurements

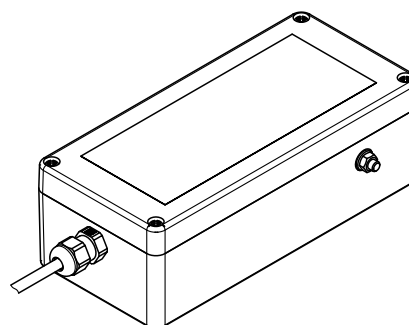

TYPE

GSER 3

Rated frequency f_r	50 Hz 60 Hz *
Rated insulation level	6/10/20 kV
Temperature category	-5 °C / +40 °C
Mass	1,2 kg
Insulating class	E
Insulation level at secondary terminals	n/a
Rated primary voltage U_{pr}	$5/\sqrt{3}$ kV *
Rated secondary voltage U_{sr}	$3,25/\sqrt{3}$ V *
Rated voltage factor F_V	1,2 / 1,9 8 h
Rated burden R_{br}	2 M Ω / 50 pF *
Accuracy class	0,1P
Rated phase offset φ_{or}	0°

* Other values available on request

DIMENSIONAL DRAWING

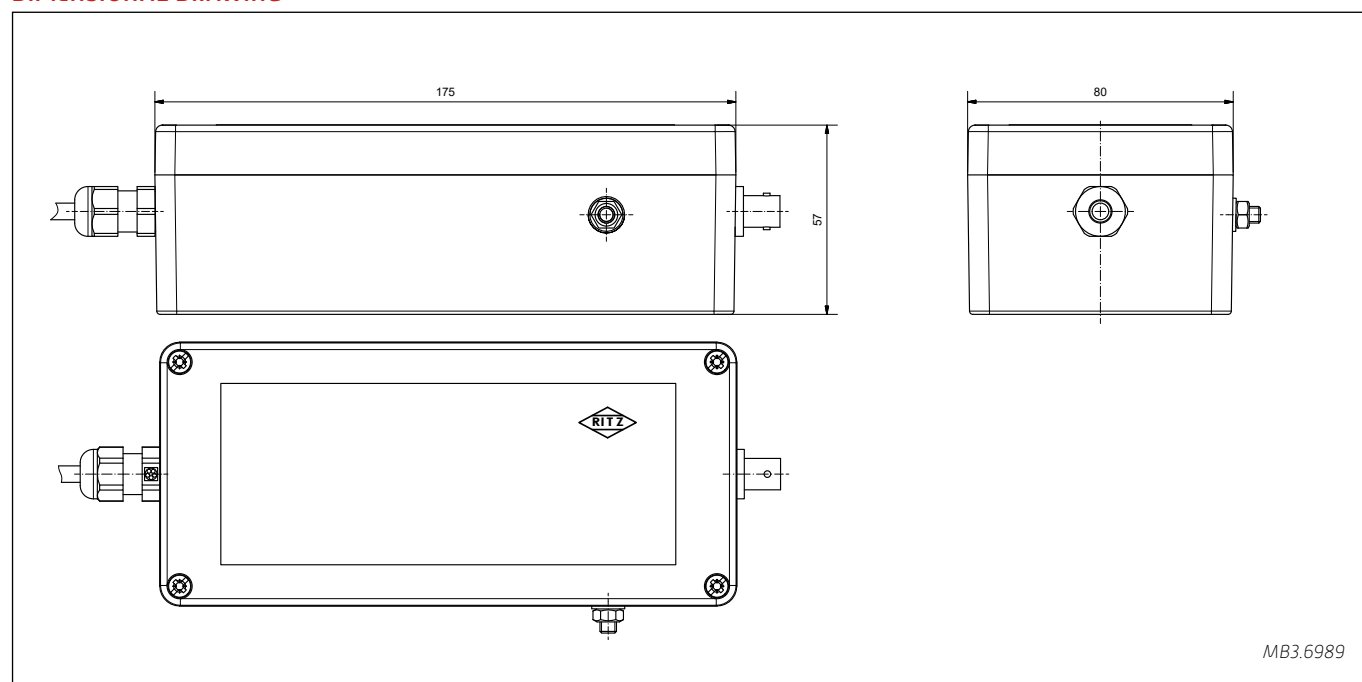

MB3.6989

For more information, please refer to the data sheet. Subject to technical modifications. NOTE: For possible secondary cables refer to Appendix 1

5.0 VOLTAGE SENSORS – OUTDOOR

5.1 GSER(F) 16

Low power passive voltage transformer according to IEC 61869-11

- Indoor or outdoor version
- Also available as an electronic voltage transformer
- Suitable for PQ measurements

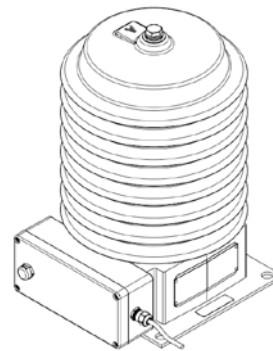

TYPE

GSER(F) 16

Rated frequency f_r	50 Hz 60 Hz *
Rated insulation level	36/70/170 kV *
Temperature category	-25 °C / +40 °C
Mass	20 kg
Insulating class	E
Insulation level at secondary terminals	n/a
Rated primary voltage U_{pr}	30/ $\sqrt{3}$ kV *
Rated secondary voltage U_{sr}	3,25/ $\sqrt{3}$ V *
Rated voltage factor F_V	1,2 / 1,9 8 h
Rated burden R_{br}	2 M Ω / 50 pF *
Accuracy class	0,2P ** 1P
Rated phase offset φ_{or}	0°

* Other values available on request / ** Temperature category: -5 °C / +40 °C

DIMENSIONAL DRAWING

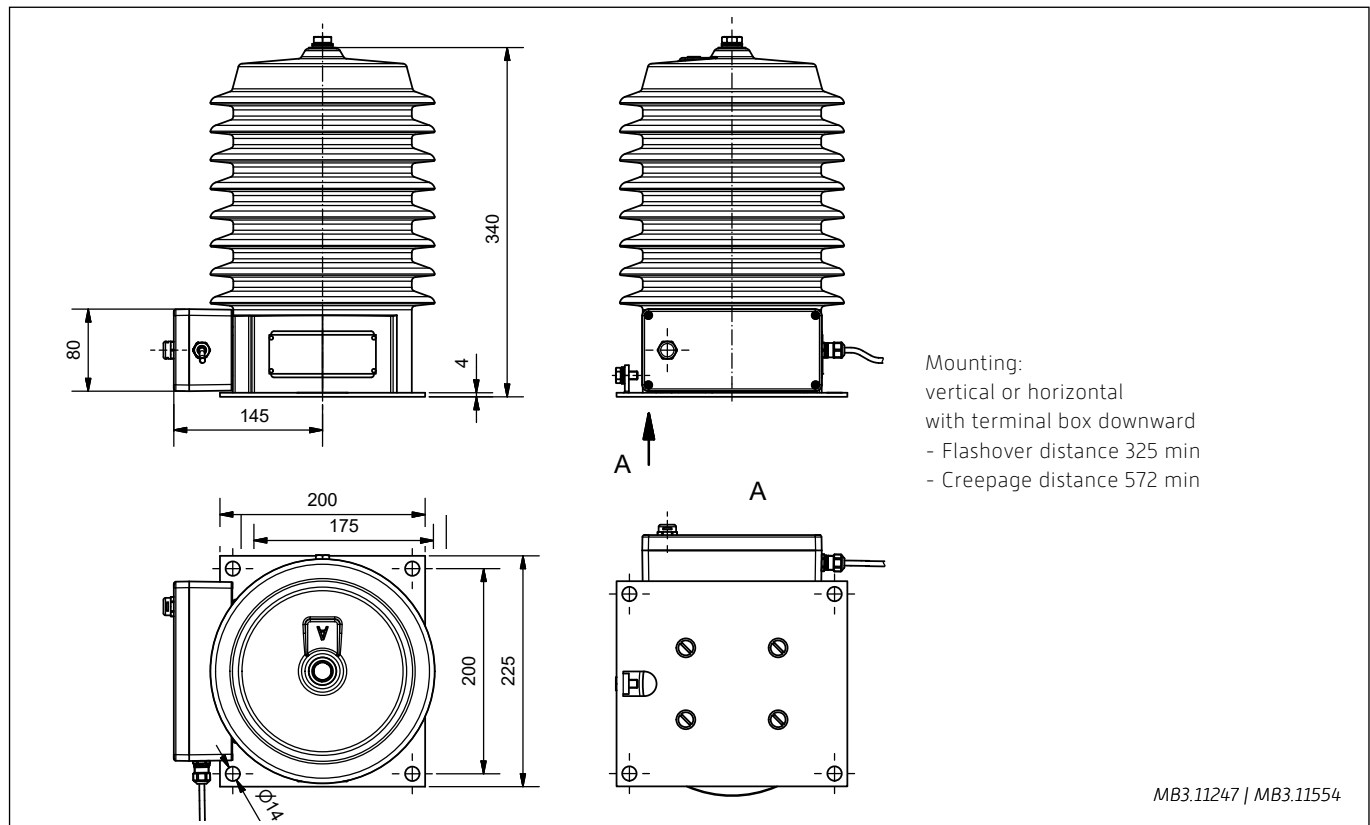

MB3.11247 | MB3.11554

For more information, please refer to the data sheet. Subject to technical modifications. NOTE: For possible secondary cables refer to Appendix 1

VOLTAGE SENSORS – OUTDOOR

5.2 GSER(F) 52

Low power passive voltage transformer according to IEC 61869-11

- Indoor or outdoor version
- Also available as an electronic voltage transformer

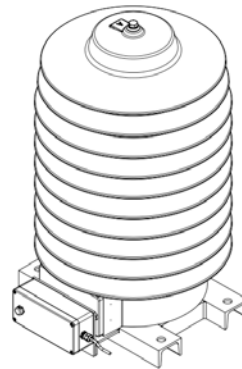

TYPE

GSER(F) 52

Rated frequency f_r	50 Hz 60 Hz *
Rated insulation level	52/95/250 kV *
Temperature category	-25 °C / +40 °C
Mass	100 kg
Insulating class	E
Insulation level at secondary terminals	n/a
Rated primary voltage U_{pr}	45/√3 kV *
Rated secondary voltage U_{sr}	3,25/√3 V *
Rated voltage factor F_V	1,2 / 1,9 8 h
Rated burden R_{br}	2 MΩ / 50 pF *
Accuracy class	0,2P ** 1P
Rated phase offset φ_{or}	0°

* Other values available on request / ** Temperature category: -5 °C / +40 °C

DIMENSIONAL DRAWING

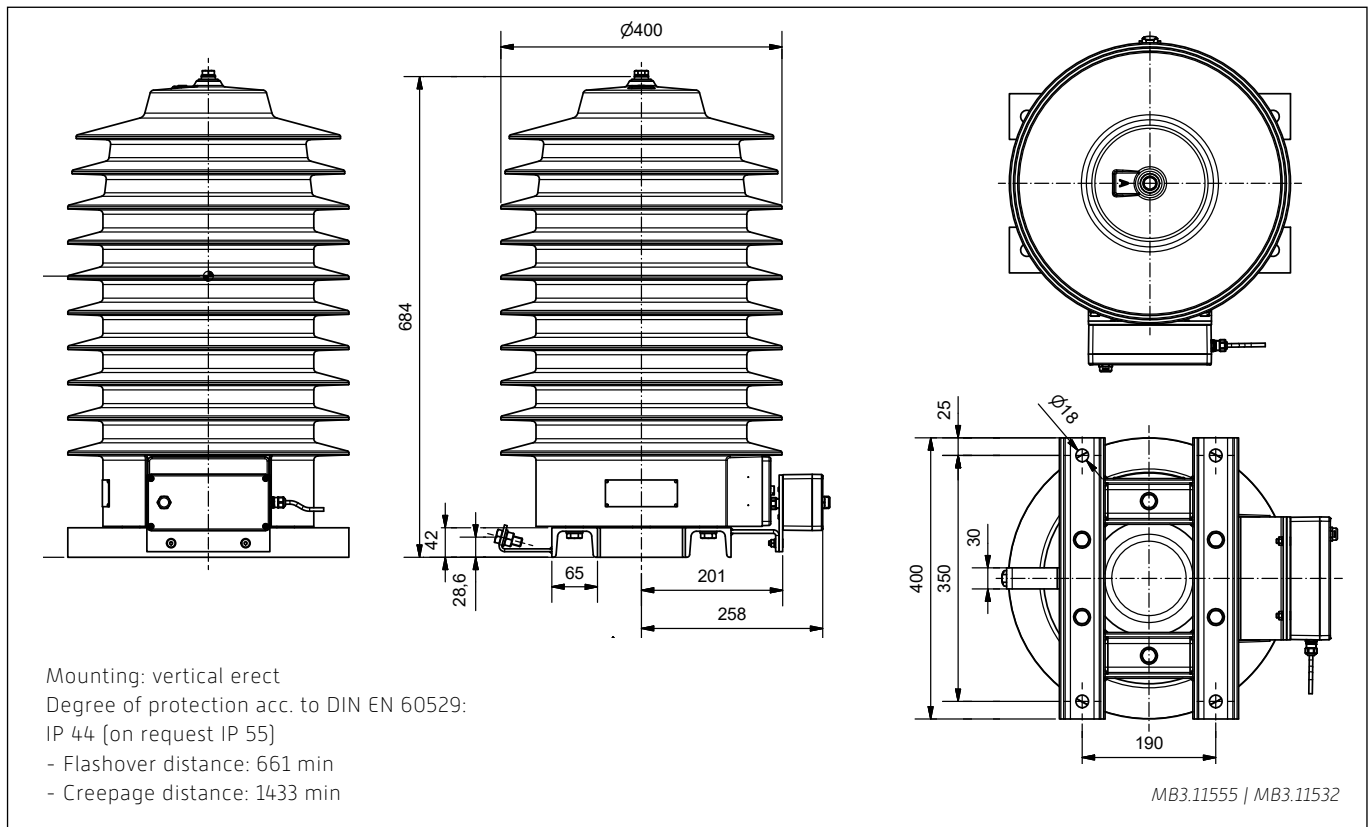

For more information, please refer to the data sheet. Subject to technical modifications. NOTE: For possible secondary cables refer to Appendix 1

VOLTAGE SENSORS – OUTDOOR

5.3 GSR 27 | 38

Low power passive voltage transformer according to IEC 61869-11

- Suitable for Recloser applications

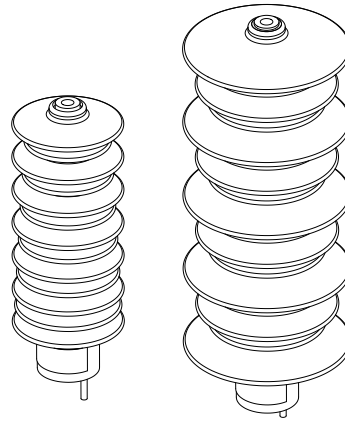

TYPES	GSR 27	GSR 38
Rated frequency f_r	50 Hz 60 Hz	
Rated insulation level	27/70/150 kV	38/95/200 kV
Temperature category	-40 °C / +60 °C	
Mass	1,6 kg	3,5 kg
Insulating class	E	
Insulation level at secondary terminals	820/1500 V	
Rated primary voltage U_{pr}	$27/\sqrt{3}$ kV	$38/\sqrt{3}$ kV
Rated secondary voltage U_{sr}	$3,25/\sqrt{3}$ V	
Rated voltage factor F_V	1,2 / 1,9 8 h	
Rated burden R_{br}	> 1 M Ω	
Accuracy class	3	
Rated phase offset φ_{or}	-	

DIMENSIONAL DRAWING

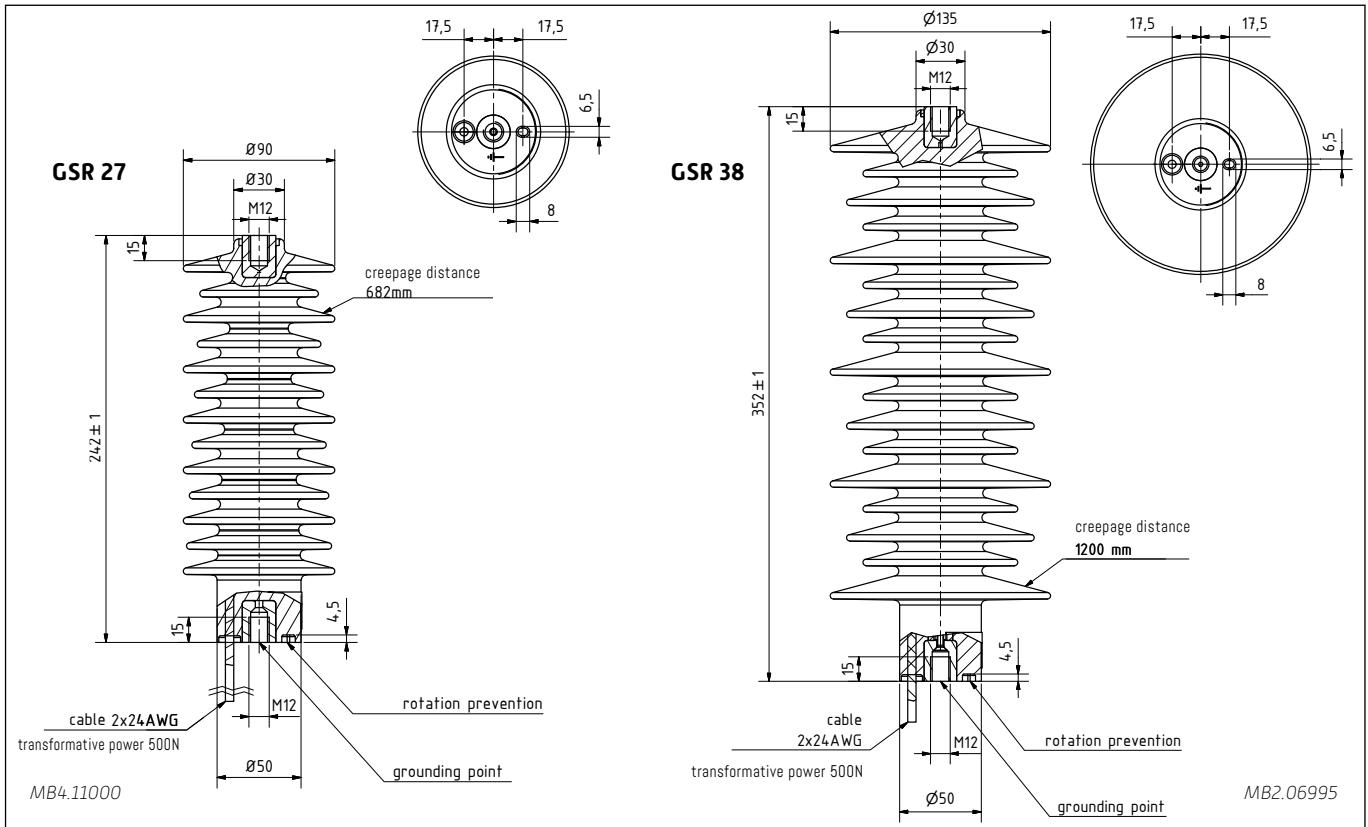

For more information, please refer to the data sheet. Subject to technical modifications. NOTE: For possible secondary cables refer to Appendix 1

6.0 COMBINED SENSORS

6.1 ABS 12 | 17.5 | 24 | 36

- Rogowski technology
- Non-saturating for current measurement
- Support design according to DIN 42600 and IEC 61869-06
- For installation in air-insulated switchgear
- With coupling electrode for voltage indication

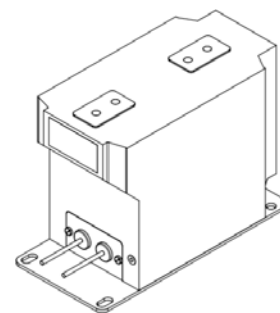

TYPES	ABS 12	ABS 17.5	ABS 24	ABS 36
Rated frequency f_r	50 Hz 60 Hz			
Rated insulation level	12/28/75 kV	17,5/38/95 kV	24/50/125 kV	36/70/170 kV
Temperature category	-5 °C / +40 °C			
Mass	18...22 kg		26...36 kg	45 kg
Insulating class	E			
Insulation level at secondary terminals	820/1500 V			
Rated primary current I_{pr}	250 A *			
Rated secondary voltage U_{sr}	150 mV			
Factor of the extended primary rated current K_{pcr}	10			
Rated short-time thermal current I_{th}	31,5 kA 3 s			
Rated peak current I_{dyn}	100 kA			
Rated continuous thermal current I_{cth}	2500 A			
Current sensor accuracy class	0,5			
Current sensor output signal	derivative			
Current sensor rated phase offset	90°			
Rated primary voltage U_{pr}	10/ $\sqrt{3}$ kV	15/ $\sqrt{3}$ kV	20/ $\sqrt{3}$ kV	30/ $\sqrt{3}$ kV
Rated secondary voltage U_{sr}	1/ $\sqrt{3}$ V	1,5/ $\sqrt{3}$ V	2/ $\sqrt{3}$ V	1,5/ $\sqrt{3}$ V
Rated voltage factor F_V	1,2 / 1,9 8 h			
Voltage sensor accuracy class	0,5 1 3P			
Rated burden R_{br}	2 M Ω / 50 pF *			
Voltage sensor output signal	proportional			

* Other values available on request

DIMENSIONAL DRAWING

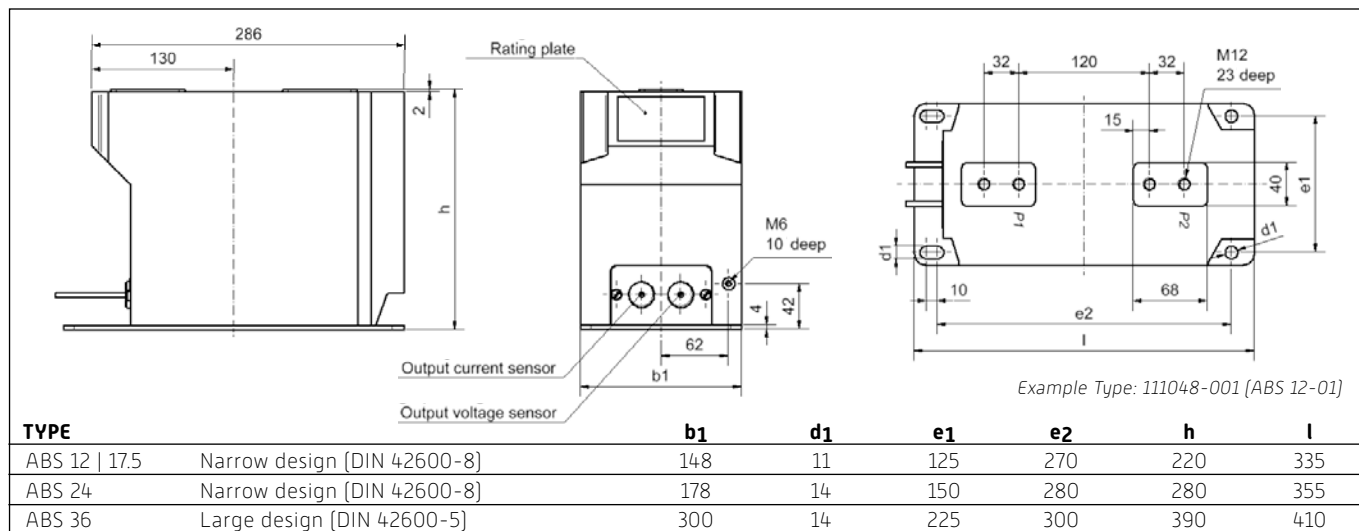

For more information, please refer to the data sheet. Subject to technical modifications. NOTE: For possible secondary cables refer to Appendix 1

7.0 APPENDIX 1: SECONDARY TERMINALS

The following table lists the cables, connectors and cable lengths used for the secondary terminals. Other configurations are also possible on request.

	CABLE	CONNECTION / CONNECTOR	LENGTH
Window type current sensors			
KSOH-S 1082	LiYCY 2 x 0,25 mm ²	Open ends	5 m
MKSOH-S 1384	LiYCY 2 x 0,25 mm ²	Open ends	5 m
KSR-S 60 size1	-	Terminals	-
Split core current sensors			
UGSS-S 104 *	-	Terminals	-
RKU-S 2012 *	-	Terminals	-
Current sensors in block design			
ASG 24-63 36-63	RJ45; CAT6A, green	RJ 45	3,6 m
ASG 24-36 36-36	RJ45; CAT6A, green	RJ 45	3,6 m
Voltage sensors indoor			
MGTK 12 17.5 24	LiYCY-OB	M8, 3-pole	0,2 m
MGTK-V 12 17.5 24	LiYCY-OB	M8, 3-pole	0,2 m
Voltage sensors outdoor			
GSER(F) 16	RG 58C/U	BNC	5 m
GSER(F) 52	RG 58C/U	BNC	5 m
GSR 27 38	LS9YC11Y 2x24 AWG	Open ends	< 10 m
Combination sensors			
ABS 12 17.5 24 36	LiYSTCYC11Y / YDDY cat6	Twin BNC / RJ 45	5 m

* The connecting cable is not included in the scope of delivery. It can be ordered in addition if required.

8.0 APPENDIX 2: ACCURACY CLASSES ACCORDING TO IEC 61869

8.1 LIMITS AT RATED FREQUENCY

CURRENT SENSORS FOR MEASURING PURPOSES

Accuracy class	RATIO ERROR ϵ [%]					PHASE ERROR φ_e [']				
	0,01 I_{pr}	0,05 I_{pr}	0,2 I_{pr}	I_{pr}	$K_{pcr} \times I_{pr}$	0,01 I_{pr}	0,05 I_{pr}	0,2 I_{pr}	I_{pr}	$K_{pcr} \times I_{pr}$
0,1	-	$\pm 0,4$	$\pm 0,2$	$\pm 0,1$		-	± 15	± 8	± 5	
0,2	-	$\pm 0,75$	$\pm 0,35$	$\pm 0,2$		-	± 30	± 15	± 10	
0,2S	$\pm 0,75$	$\pm 0,35$		$\pm 0,2$		± 30	± 15		± 10	
0,5	-	$\pm 1,5$	$\pm 0,75$	$\pm 0,5$		-	± 90	± 45	± 30	
0,5S	$\pm 1,5$	$\pm 0,75$		$\pm 0,5$		± 90	± 45		± 30	
1	-	$\pm 3,0$	$\pm 1,5$	$\pm 1,0$		-	± 180	± 90	± 60	
3	-	-	$\pm 4,5$	$\pm 3,0$		-	-	-	-	-

Permissible ratio and phase error for current sensors according to IEC 61869-10:2017, Table 1001

CURRENT SENSORS FOR PROTECTION PURPOSES

Accuracy class	RATIO ERROR ϵ [%]	PHASE ERROR φ_e [']	TOTAL ERROR [%]
	I_{pr}	I_{pr}	Rated accuracy limit primary current
5P	1	60	5
10P	3	60	10

Permissible ratio and phase errors for current sensors according to IEC 61869-10:2017, Table 1002

VOLTAGE SENSORS FOR MEASURING PURPOSES

Accuracy class	RATIO ERROR ϵ [%]			PHASE ERROR φ_e [']		
	0,8 U_{pr}	U_{pr}	1,2 U_{pr}	0,8 U_{pr}	U_{pr}	1,2 U_{pr}
0,1		$\pm 0,1$			± 5	
0,2		$\pm 0,2$			± 10	
0,5		$\pm 0,5$			± 20	
1		$\pm 1,0$			± 40	
3		$\pm 3,0$			-	

Permissible ratio and phase error for voltage sensors according to IEC 61869-11:2017, Table 1101

VOLTAGE SENSORS FOR MEASURING AND/OR PROTECTION PURPOSES

Accuracy class	RATIO ERROR ϵ [%]					PHASE ERROR φ_e [']				
	0,02 U_{pr}	0,2 U_{pr}	0,8 U_{pr}	U_{pr}	$FV \times U_{pr}$	0,02 U_{pr}	0,2 U_{pr}	0,8 U_{pr}	U_{pr}	$FV \times U_{pr}$
0,1P	$\pm 0,5$	$\pm 0,2$		$\pm 0,1$		± 20	± 10		± 5	
0,2P	± 1	$\pm 0,4$		$\pm 0,2$		± 40	± 20		± 10	
0,5P	± 2	± 1		$\pm 0,5$		± 80	± 40		± 20	
1P	± 4	± 2		± 1		± 160	± 80		± 40	
3P	± 6			± 3		± 240			± 120	
6P	± 12			± 6		± 480			± 240	

Permissible ratio and phase error for voltage sensors according to IEC 61869-11:2017, Table 1102

For more information, please refer to the data sheet. Subject to technical modifications.

ACCURACY CLASSES ACCORDING TO IEC 61869

8.2 LIMITS FOR HARMONICS

Accuracy class	PHASE ERROR ϵ [%] Harmonic							$\Delta\varphi$ [°]	PHASE ERROR φ_e [°] Harmonic				
	0 Hz	1 Hz	2 to 4	5 and 6	7 bis 9	10 to 13	> 13		1 Hz	2 to 4	5 and 6	7 to 9	10 to 13
0,1	+1 -100	+1 -30	±1	±2	±4	±8	+8 -100	±45	±1	±2	±4	±8	
0,2 0,2S	+2 -100	+2 -30	±2	±4	±8	±16	+16 -100	±45	±2	±4	±8	±16	
0,5 0,5S	+5 -100	+5 -30	±5	±10	±20	±20	+20 -100	±45	±5	±10	±20	±20	
1	+10 -100	+10 -30	±10	±20	±20	±20	+20 -100	±45	±10	±20	±20	±20	

Accuracy classes according to IEC 61869-6:2016, Table 6A.2

Accuracy class	PHASE ERROR ϵ [%]			PHASE ERROR φ_e [°]		
	$0,1 \leq f < 1$ kHz	$1 \leq f < 1,5$ kHz	$1,5 \leq f < 3$ kHz	$0,1 \leq f < 1$ kHz	$1 \leq f < 1,5$ kHz	$1,5 \leq f < 3$ kHz
0,1	±1	±2	±5	±1	±2	±5
0,2 0,2S	±2	±4	±5	±2	±4	±5
0,5 0,5S	±5	±10	±10	±5	±10	±20
1	±10	±20	±20	±10	±20	±20

Accuracy class extension up to 3 kHz according to IEC 61869-6:2016, Table 6A.3

Accuracy class	PHASE ERROR ϵ [%]			PHASE ERROR φ_e [°]		
	$0,1 \leq f < 5$ kHz	$5 \leq f < 10$ kHz	$10 \leq f < 20$ kHz	$0,1 \leq f < 5$ kHz	$5 \leq f < 10$ kHz	$10 \leq f < 20$ kHz
0,1	±1	±2	±5	±1	±2	±5
0,2 0,2S	±2	±4	±5	±2	±4	±5
0,5 0,5S	±5	±10	±10	±5	±10	±20
1	±10	±20	±20	±10	±20	±20

Accuracy class extension up to 20 kHz according to IEC 61869-6:2016, Table 6A.4

Accuracy class	PHASE ERROR ϵ [%]			PHASE ERROR φ_e [°]		
	$0,1 \leq f < 5$ kHz	$5 \leq f < 10$ kHz	$10 \leq f < 150$ kHz	$0,1 \leq f < 5$ kHz	$5 \leq f < 10$ kHz	$10 \leq f < 150$ kHz
0,1	±1	±2	±5	±1	±2	-
0,2 0,2S	±2	±4	±5	±2	±4	-
0,5 0,5S	±5	±10	±10	±5	±10	-
1	±10	±20	±20	±10	±20	-

Accuracy class extension up to 150 kHz

For more information, please refer to the data sheet. Subject to technical modifications.

ACCURACY CLASSES ACCORDING TO IEC 61869

8.3 ACCURACY DEPENDING ON PRIMARY CONDUCTOR POSITION

ADDITION	MAX. POSITION FACTOR PF	MAX. ANGLE α [°]
A1	0	0
A2	0,5	15
A3	1	45

According to IEC 61869-10:2017, Table 10D.1

CALCULATION OF POSITION FACTOR

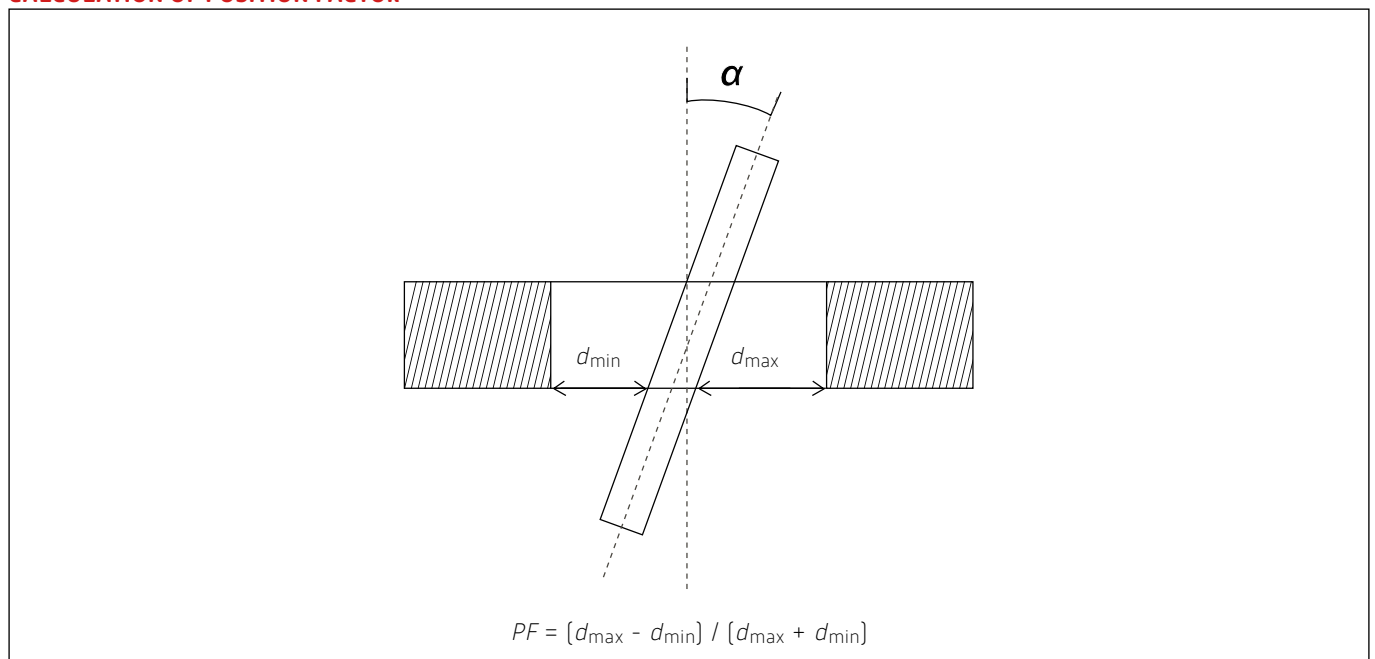

For more information, please refer to the data sheet. Subject to technical modifications.

Empowering Our Electrical Future

RITZ is one of the leading specialists worldwide in the field of instrument transformers, cast resin applications and cast resin insulated bus bar systems.

The origins of the company date back to 1904. Today, the RITZ parent company in Hamburg combines the experience of „RITZ Messwandler (RITZ)“, „Messwandlerbau Bamberg (MWB)“, the „Transformatoren- und Röntgenwerk“ in Dresden (TuR and Duromer) and the „Wandler- und Transformatoren-Werk Wirges (WTW)“.

RITZ owns seven production sites, spread across Europe, China and the United States of America.

Our customers include well known companies from the energy supply sector and electrical industries throughout the world.

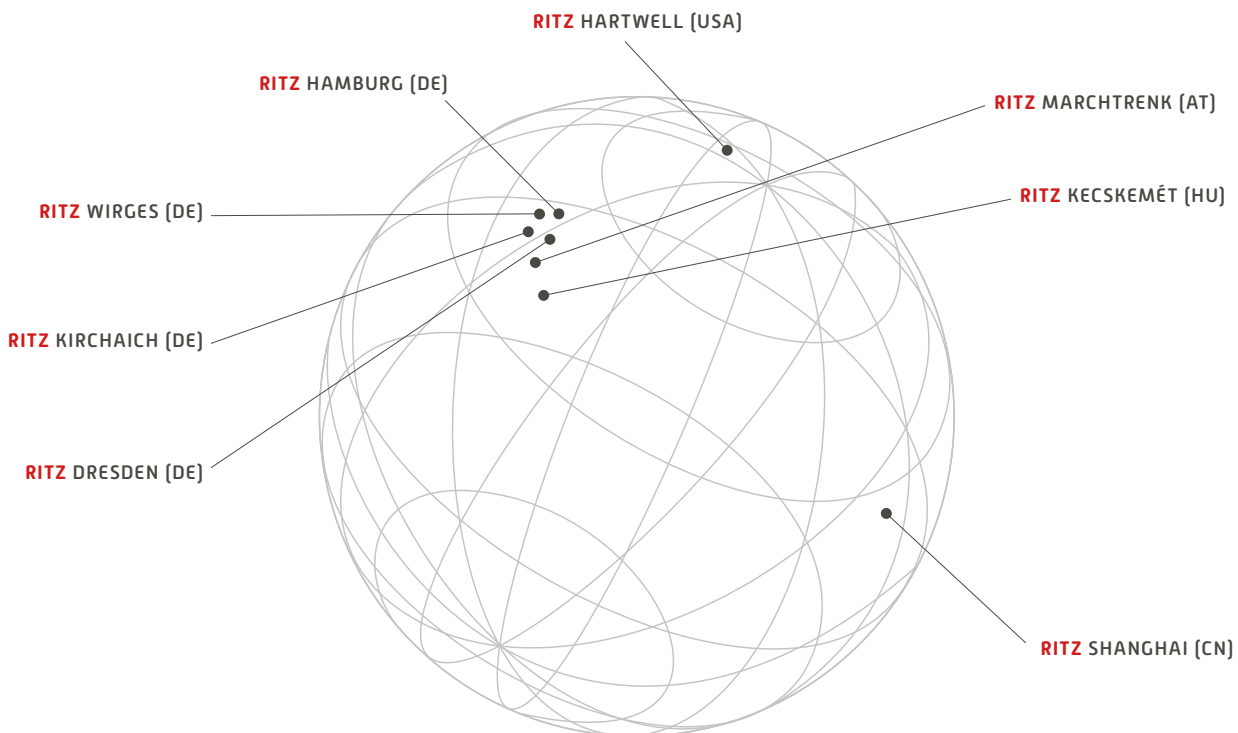

GROUP HISTORY

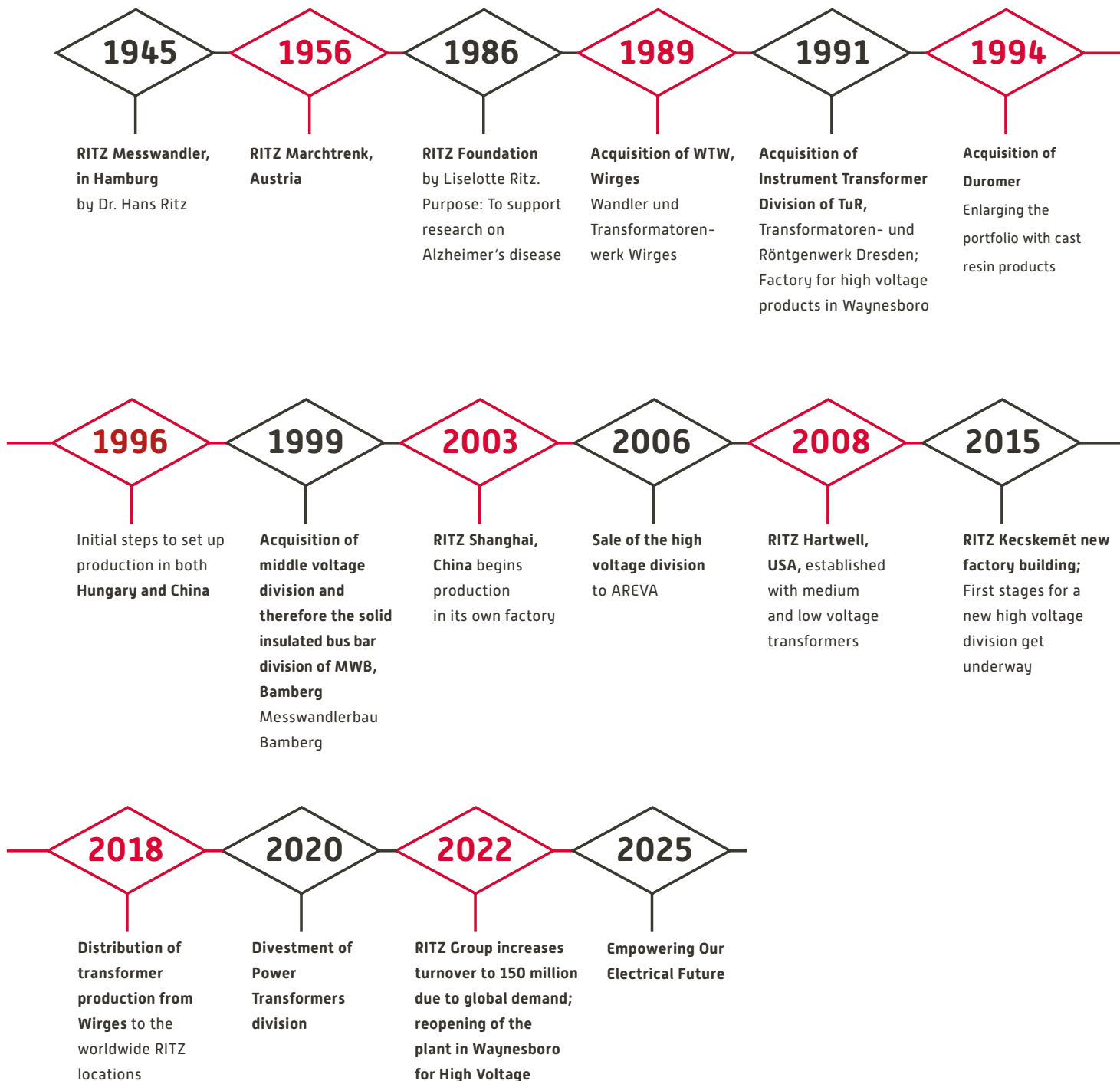

Disclaimer: Errors and omissions excepted. Subject to technical modifications. Images for reference only.

Empowering Our Electrical Future



GERMANY: RITZ HAMBURG | RITZ WIRGES | RITZ KIRCHAICH | RITZ DRESDEN

AUSTRIA: RITZ MARCHTRENK

HUNGARY: RITZ KECSKEMÉT

USA: RITZ HARTWELL | WAYNESBORO

CHINA: RITZ SHANGHAI

RITZ INSTRUMENT TRANSFORMERS GmbH

Wandsbeker Zollstr. 92-98
22041 Hamburg
Germany

Phone: +49 40 511 23 - 0
Fax: + 49 40 511 23 - 111
Email: info@ritz-international.com

We are the leading specialist for instrument transformers, cast resin parts and bus bars with cast resin insulation.

We not only develop your standard equipment, but also transform your ideas into customised products. In exact accordance with your requirements!
For more information visit www.ritz-international.com or contact us at info@ritz-international.com



www.ritz-international.com